

# WINCHE ELÉCTRICO KDJ-10000E<sub>1</sub>

**CDT**  
INDUSTRIAL

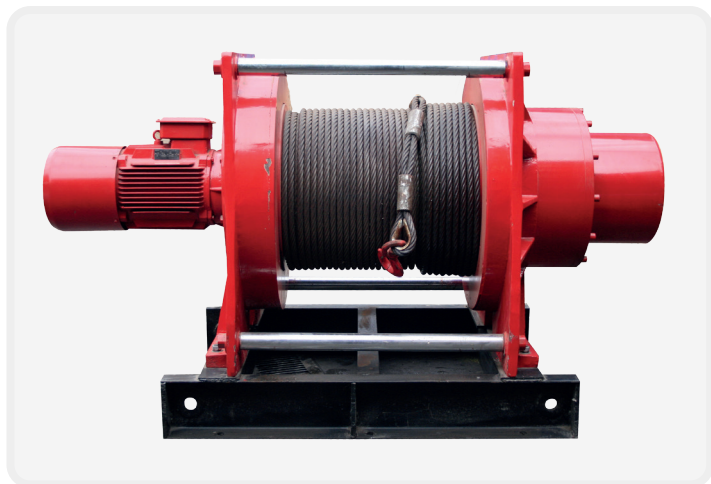

MODELO	KDJ-10000E <sub>1</sub>
Carga Nominal (kgs)	10.000
Velocidad (mts/min)	11
Motor (kw x polos)	22 X 6
Voltaje (V)	380
Amperaje (A)	44.6
Frecuencia (Hz)	50
Largo Util del Cable (mts)	235
Cable de Acero ( Ø mm x mts)	32 x 250
Construccion del Cable	6 x 37 Alma de Fibra
Peso Neto (kgs)	3.080
Tasa de Trabajo	S3 - 25%

DIMENSIONES (mm)	
A	6 - Ø 28
B	1140
C	950
D	2510
E	1015
F	1260
G	840
H	Ø 450

- Incluye control de velocidad por VDF.
- Incluye Resistencia de freno.

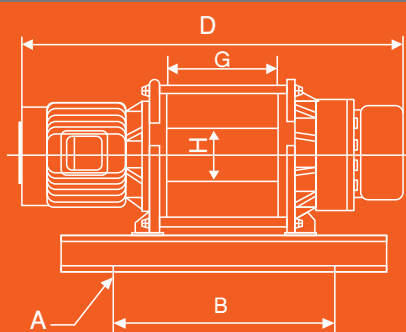
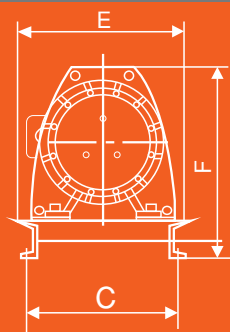

dimensiones

