

WINCHE ELÉCTRICO KDJ-2200E1

CDT
INDUSTRIAL

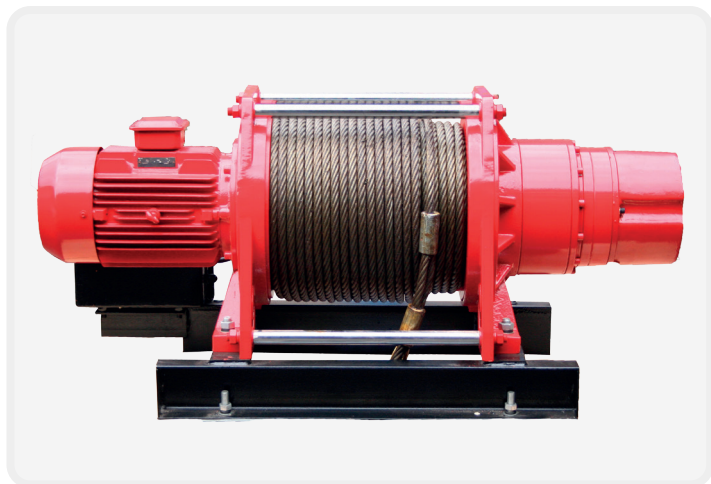

MODELO	KDJ-2200E1
Carga Nominal (kgs)	2.200
Velocidad (mts/min)	10
Motor (kw x polos)	6 x 4
Voltaje (V)	380
Amperaje (A)	12
Frecuencia (Hz)	50
Largo Util del Cable (mts)	97
Cable de Acero (Ø mm x mts)	16 x 100
Construccion del Cable	6 x 37 Alma de Fibra
Peso Neto (kgs)	450
Tasa de Trabajo	S3 - 25%

DIMENSIONES (mm)	
A	4 - Ø 20
B	600
C	510
D	1250
E	565
F	658
G	315
H	Ø 178

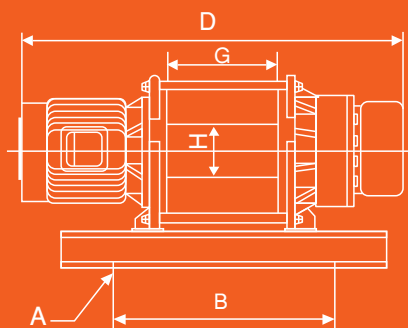
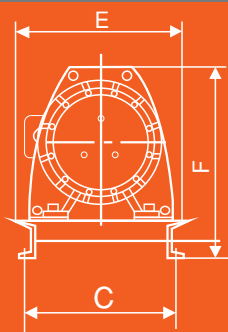

dimensiones

