

WINCHE ELÉCTRICO KDJ-500E1

CDT
INDUSTRIAL

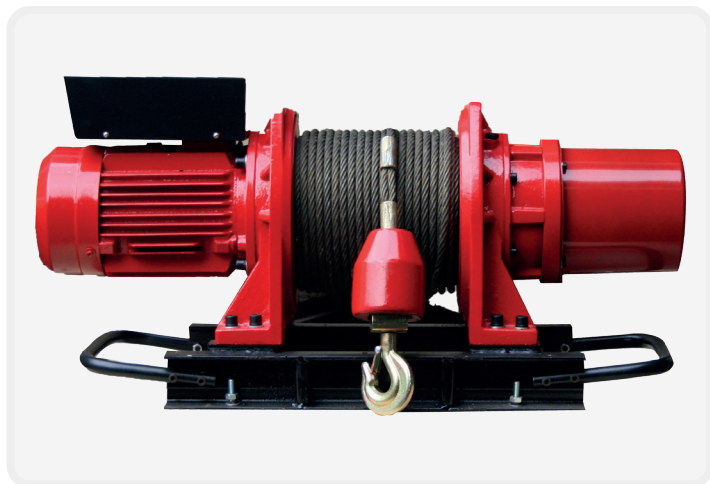

MODELO	KDJ-500E1
Carga Nominal (kgs)	500
Velocidad (mts/min)	13
Motor (kw x polos)	2,2 x 4
Voltaje (V)	380
Amperaje (A)	4.8
Frecuencia (Hz)	50
Largo Util del Cable (mts)	58
Cable de Acero (Ø mm x mts)	9 x 60
Construccion del Cable	6 x 37 Alma de Fibra
Peso Neto (kgs)	136
Tasa de Trabajo	S3 - 25%

DIMENSIONES (mm)	
A	4 - Ø 14
B	400
C	330
D	922
E	372
F	430
G	240
H	Ø 140

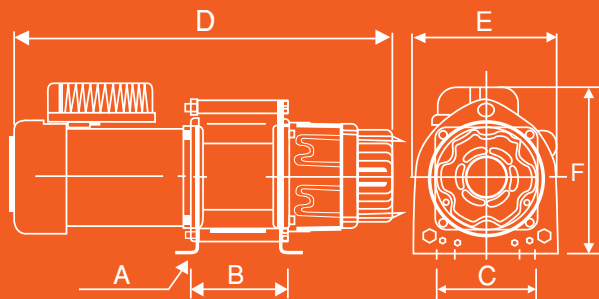
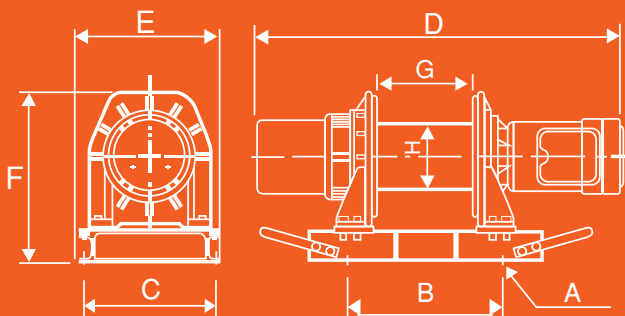

dimensiones

